

APEX
ROBOT SYSTEMS

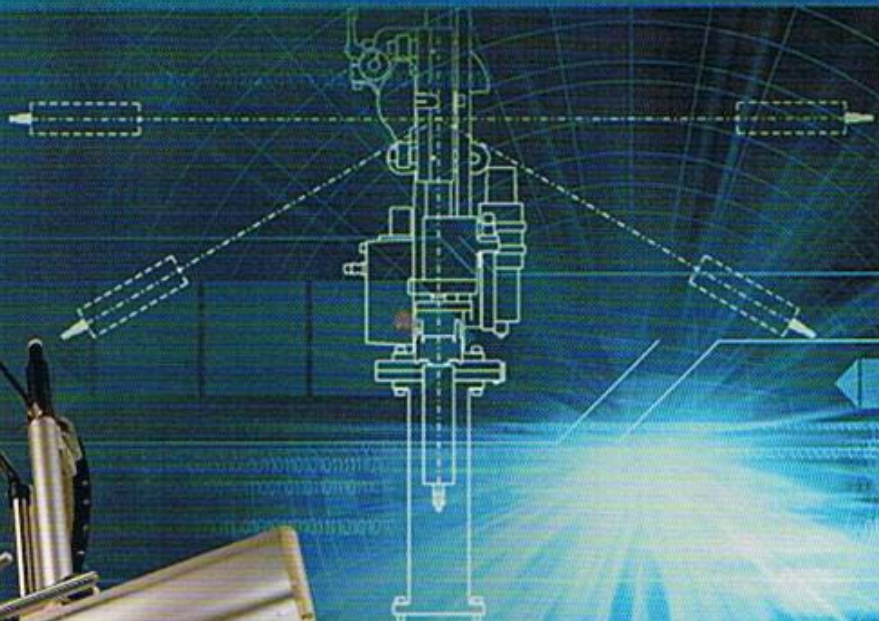

YS Series
swing-Arm

Speed. Performance.

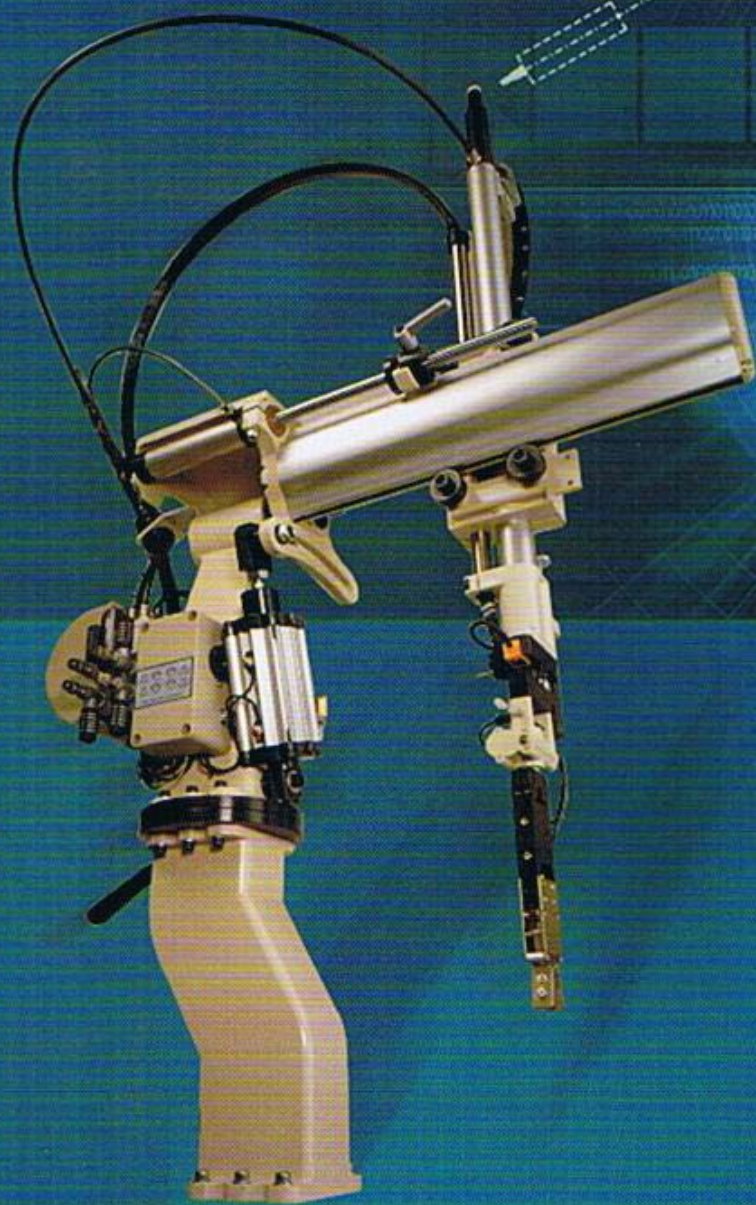
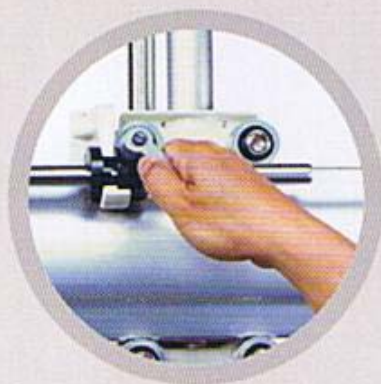

- Tool-free adjustment on kick stroke.



- Swing out direction and angle adjusted with one screw.



- Centralize pneumatic control unit. Fast reaction and durable.

- **Rapid cycle time, Rapid payback.**
- **High quality, low maintenance.**
- **Easy to install and operate.**

■ **Features.**

- 1 . Rigid constructed modular sections. Virtually maintenance and trouble-free.
- 2 . Individual movement and speed adjustment.
- 3 . Separated control unit to avoid hustle environment.
- 4 . Ten standard sequences and ten teachable sequences.
- 5 . Robot status and error message will display on pendent screen:
- 6 . Incorrect or unsafe motion cannot be accepted by the program or will showing warning message.
- 7 . SPI and EUROMAP interface.
- 8 . Re-definable HOME position for Core-Pull operation.

■ **Programming.**

- 1 . Quick start with emergency stop.
- 2 . Quality inspection program with counter setting.
- 3 . Incomplete injection detection with counter setting.
- 4 . Total injection cycle counter setting.
- 5 . Test mold counter setting.
- 6 . Alarm frequency and timer setting.
- 7 . Motion and timer delay setting.
- 8 . Reject parts detection with counter setting.
- 9 . Spray counter setting.
- 10 . Two spare output, one spare input.

■ **Optional Accessories.**

- 1 . Third mold plate movement detector.
- 2 . Standard SPI or EUROMAP plug.
- 3 . End of the arm tooling accessories.



Quality.



■ Patented pressure differential verification system. Reliable and maintenance free.



■ Simple base pivoting for ease of mold change.



■ Slimmer gripper design for tight mold open access.



ROBOT SYSTEMS

Model No.		Dry Cycle (sec.)		I.M.M. Range (Tons)	Vertical Stroke (mm)	Net Weight (kgs)	Air Consumption (l /Cycle)
		Take-Out	Cycle				
YS450	Standard Model	0.6	3.1	25~150	450	33	9
YST450	With Twist					33.5	9.2
YSTV450	With Twist & Vacuum					34	15
YS550	Standard Model	0.7	3.2	60~180	550	33.5	10
YST550	With Twist					34	10.2
YSTV550	With Twist & Vacuum					34.5	16
YS650	Standard Model	0.8	3.4	120~250	650	34	11
YST650	With Twist					34.5	11.2
YSTV650	With Twist & Vacuum					35	17
YS750	Standard Model	1.0	3.8	200~350	750	34.5	12
YST750	With Twist					35	12.2
YSTV750	With Twist & Vacuum					35.5	18
YS850	Standard Model	1.2	4.0	300~450	850	35	13
YST850	With Twist					35.5	13.2
YSTV850	With Twist & Vacuum					36	19

Comments:

- 1.YSTV-series:Fitted with vacuum generator and vacuum fittings.
- 2.Adjustable Swing Angle: 60°~90° (To operator's side or rear side).
- 3.Adjustable Gripper Rotation Angle: 60°~100°
- 4.Strip Stroke: 100 mm
- 5.Effective Payload: 4kg
- 6.Compressed Air Pressure: 4~6kg / cm²
- 7.Power Consumption: Approximately 40VA
- 8.Operation Voltage:1ϕ AC220V

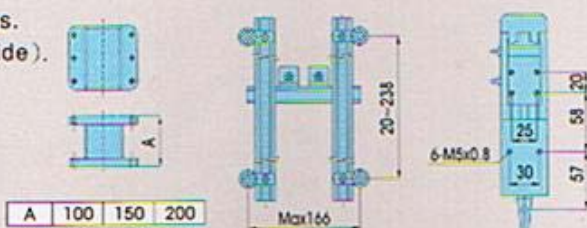

YSxxx

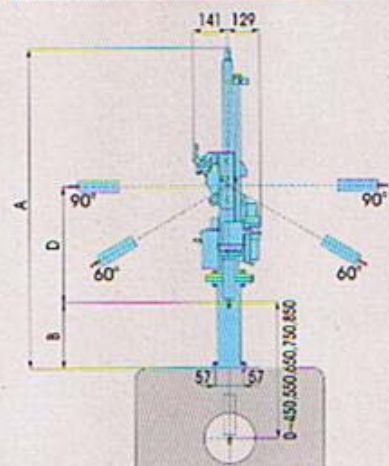

Model No.	YS450	YS550	YS650	YS750	YS850
A	1040~1240	1140~1340	1240~1440	1340~1540	1440~1640
B	115~315	115~315	115~315	75~275	75~275
C	1088~1288	1188~1388	1288~1488	1388~1588	1488~1688
D	472	472	472	512	512

YSTxxx & YSTVxxx

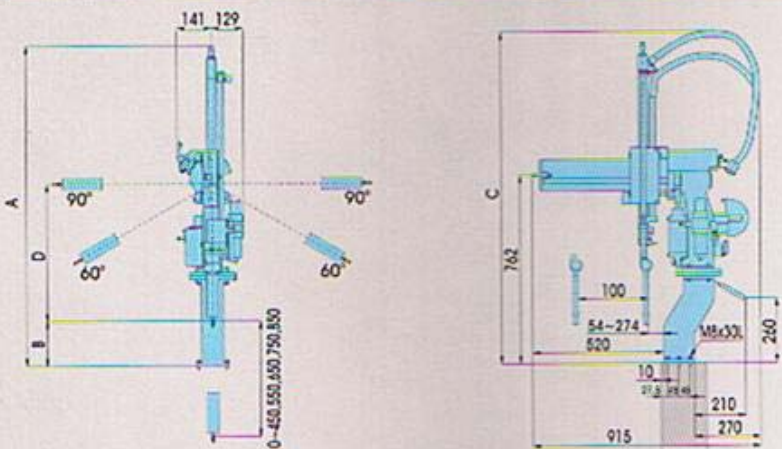

Model No.	YSTV450	YSTV550	YSTV650	YSTV750	YSTV850
A	1040~1240	1140~1340	1240~1440	1340~1540	1440~1640
B	35~235	35~235	35~235	0~190	0~190
C	1088~1288	1188~1388	1288~1488	1388~1588	1488~1688
D	556	556	556	596	596



APEX ROBOT SYSTEMS, INC.

Headquarters: No.5, 35th Rd., Taichung industrial park,
Taichung City, Taiwan, R.O.C.

Tel: 886-4-23594239 (8Lines) Fax: 886-4-23597923

E-mail: sales@apexrobot.com

web site: http://www.apexrobot.com