

SCM Series

Outline Drawings

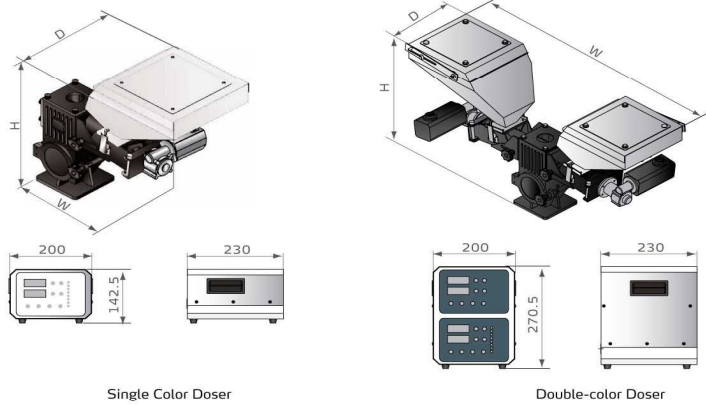

Single Color Doser

Double-color Doser

Specifications

Model	Single Color Unit										Double Color Unit		
	SCM-38-30	SCM-38-20	SCM-38-16	SCM-38-14	SCM-38-12	SCM-75-30	SCM-75-20	SCM-75-16	SCM-75-14	SCM-75-12	SCM-D-38/38	SCM-D-38/75	SCM-D-75/75
Motor Power (kW) (50/60Hz)	0.06	0.06	0.06	0.06	0.06	0.06	0.06	0.06	0.06	0.06	0.06 × 2	0.06 × 2	0.06 × 2
Output Power of Mixer (kW, 50 / 60Hz)	0.09	0.09	0.09	0.09	0.09	0.09	0.09	0.09	0.09	0.09	0.09	0.09	0.09
Screw External Dia. (mm)	30	20	16	14	12	30	20	16	14	12	**	**	**
Output Capacity (kg/hr)	14-123	7-60	1.1-32	0.6-20	0.3-10	6-62	4.4-34	0.5-15	0.2-8	0.1-4	*	*	*
Storage Hopper (L)	10	10	10	10	10	10	10	10	10	10	10	10	10
Gear Ratio	38:1	38:1	38:1	38:1	38:1	75:1	75:1	75:1	75:1	75:1	38:1/38:1	38:1/75:1	75:1/75:1
Main Material Hopper (L)	Optional(15)	Optional(15)	Optional(15)	Optional(15)	Optional(15)	Optional(15)	Optional(15)	Optional(15)	Optional(15)	Optional(15)	Optional(15)	Optional(15)	Optional(15)
Mixer	Optional	Optional	Optional	Optional	Optional	Optional	Optional	Optional	Optional	Optional	Optional	Optional	Optional
Floor Stand	Optional	Optional	Optional	Optional	Optional	Optional	Optional	Optional	Optional	Optional	Optional	Optional	Optional
Dimensions													
H(mm)	520	520	520	520	520	520	520	520	520	520	615	615	615
W(mm)	610	610	610	610	610	610	610	610	610	610	1045	1045	1045
D(mm)	335	335	335	335	335	335	335	335	335	335	335	335	335
Weight (kg)	29	29	29	29	29	29	29	29	29	29	50	50	50

Notes: 1) ** stands for the output capacity depends on model selected, data of the single color doser can be a reference. For example: SCM-D-38-16 / 38-14, output capacity 1.7-52kg/hr.
 2) *** stands for external dia. of screw is up to model selected.
 3) For additional mixer, add "M5" at the end of model code.
 4) All output capacities of above models are base on data from bulk density 1.2kg/L, dia. 2-3mm masterbatch in a test criteria of continuous running.
 5) Main power for single color unit is 1Φ, 115 / 230V, 50 / 60Hz, but it will be 3Φ, 230 / 400 / 460 / 575VAC, 50 / 60Hz when being equipped with mixer.

We reserve the right to change specifications without prior notice.