

SGD Series

Outline Drawings

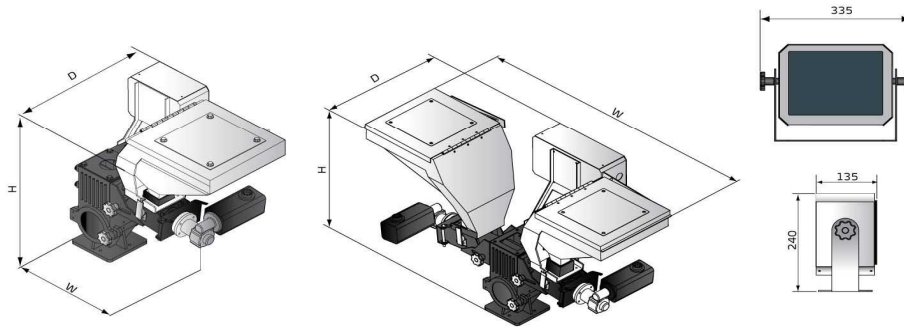

Specifications

Model	Single Color Unit			Double Color Unit
	SGD-12	SGD-14	SGD-16	SGD-D
Motor Power (kW) (50/60Hz)	0.06	0.06	0.06	0.06×2
Output Power of Mixer (kW, 50 / 60Hz)	0.09	0.09	0.09	0.09
Screw External Dia. (mm)	12	14	16	**
Output Capacity (kg/hr)	0.04-3.6	0.6-20	1.1-32	*
Storage Hopper (L)	10	10	10	10
Gear Ratio	38:1	38:1	38:1	38:1/38:1
Main Material Hopper (L)	Optional (15)	Optional (15)	Optional (15)	Optional (15)
Mixer	Optional	Optional	Optional	Standard
Heavy Base	Optional	Optional	Optional	Optional
Dimensions				
H(mm)	580	580	580	624
W(mm)	600	600	600	1060
D(mm)	430	430	430	430
Weight (kg)	40	40	40	60

Notes: 1) ** stands for the output capacity depends on model selected, data of the single color doser can be a reference. For example: SGD-D-12/14, output: capacity 0.64-23.6kg/hr.

2) *** stands for external dia. of screw is up to model selected.

3) For additionally mount mixer on single color doser, add "MS" at the end of the model code.

4) All output capacities from above models are based on data from bulk density 1.2kg/L, dia. 2-3mm masterbatch in a test criteria of continuous running.

5) Power supply: 1Φ, 115/230V, 50/60Hz.

We reserve the right to change specifications without prior notice.