

■ Application

SLD liquid doser is suitable to the measuring and feeding of liquid masterbatch.

■ Working Principle

Upon receiving the signal from injection machine or extruder, the unit will actuate the peristaltic pump with stepper based on the parameters input. Liquid masterbatch dispensing is realized by the the pressing and releasing action which pump does to the conveying hose.

■ Outline Drawing

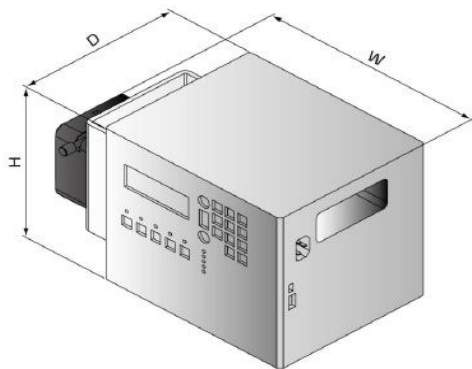

■ Specifications

Model	SLD
Motor Speed (rpm)	0.7-200
Conveying Capacity (kg/hr)	0.01-2
Dimension	
W (mm)	190
L (mm)	220
H (mm)	190
Calibration	Manual
Weight (kg)	6

Notes: 1). Power supply: 1Φ, 230VAC, 50Hz.